

Control joint seals in junctions between a lightweight partition and a concrete/masonry wall

Up to -/240/240 fire resistance in accordance with the requirements of BS 476: Part 20: 1987 and/or AS 1530: Part 4: 2005, depending on applications and types of penetrating elements

- 1a PROMASEAL®-A Acrylic Sealant for penetration seals of electrical cables and cable trays (up to -/180/- fire resistance, or up to -/120/120 fire resistance if PROMASEAL® Wrap or mesh guard is applied) in walls and partitions
- 1b PROMASEAL®-A Acrylic Sealant for penetration seals of cored hole-fixed non combustible metal pipes (up to -/120/- fire resistance, or up to -/120/120 fire resistance if PROMASEAL® Wrap or mesh guard is applied*) or cast-in non combustible metal pipes (up to -/240/- fire resistance, or up to -/120/120 fire resistance likewise*) in floors and walls
- 1c PROMASEAL®-A Acrylic Sealant for penetration seals of steel ventilation duct (up to -/240/- fire resistance) in walls and partitions
- 1d PROMASEAL®-A Acrylic Sealant for control joint seals in floors, walls and partitions; fire resistance in accordance with specifications in the table below
- 2 Polyethylene backing rods
- 3 Non combustible metal pipes up to 150mm nominal diameter
- 4 Steel wire mesh to maintain distance from combustible materials where insulation criteria is required (please consult Promat for details)
- 5 Electrical cables supported with cable tray or steel trunking
- 6 Steel ventilation duct
- 7 Fire damper
- 8 Steel angles and/or rod hangers, supported and fixed within 300mm measured from the walls
- 9 Fire resistant concrete/masonry floors or walls
- 10 Fire resistant steel/timber framed lightweight partitions

Width to depth ratio in control joint seals

Fire resistance performance / thickness of penetrating elements		Up to -/120/120 for minimum 120mm thick elements					Up to -/180/180 for minimum 150mm thick elements					Up to -/240/240 for minimum 170mm thick elements				
		10	20	30	40	50	10	20	30	40	50	10	20	30	40	50
Gap width (a)	mm	10	20	30	40	50	10	20	30	40	50	10	20	30	40	50
Fire side (b)	mm	10	10	15	-	-	10	10	15	-	-	20	20	20	-	-
Non fire side	mm	10	10	-	-	-	10	10	-	-	-	10*	10*	-	-	-
Both sides	mm	10	10	15	20	20	10	10	15	20	20	10	10	15	20	20

* Up to -/240/180 fire resistance

PROMASEAL®-A Acrylic Sealant is a water based acrylic sealant. The advantages of water based sealant is in making post installation and/or site clean up very easy. It is also environmentally friendly. If installed correctly and once cured, PROMASEAL®-A Acrylic Sealant should not crack and it can be simply over painted. It has good resistance to water characteristics and some movement capabilities.

There are, however, some key points to remember:

- PROMASEAL®-A Acrylic Sealant is not recommended as an external water seal.
- It should not be used where continuous water immersion is likely.
- It should not be used in areas where the atmosphere is continually wet or damp, e.g. bathrooms.
- It is not recommended for use in high movement joints. In fact, PROMASEAL®-A Acrylic Sealant should not be employed in joints that require more than ±15% movement.

General Application Considerations

PROMASEAL®-A Acrylic Sealant will adhere to a wide range of surfaces. All common foam backer rods are suitable as bond breakers. Surfaces do not need priming if dust free. If in doubt, apply the diluted (by adding 50% water) PROMASEAL®-A Acrylic Sealant to the surfaces by brush.

It is essential that the correct width to depth ratio of PROMASEAL®-A Acrylic Sealant is maintained in control joint seals (see table on page 28).

In order to cure correctly, PROMASEAL®-A Acrylic Sealant must not be subjected to high humidity or moisture during the curing period. Please refer to **Exterior And Fire Resistant Seals In Control Joints** below.

PROMASEAL®-A Acrylic Sealant should not be applied if the air temperature is below 5°C or above 35°C. If the prevailing ambient temperature is outside this range it may effect the curing of the sealant; the surface temperature of the separating elements must also be taken into consideration.

Maintenance

Painting

Once properly cured, PROMASEAL®-A Acrylic Sealant may be finished and is compatible with most paints. Please confirm the compatibility of the paint and sealant by conducting a small scale test sample before use.

Clean Up

PROMASEAL®-A Acrylic Sealant is water based and can thus be cleaned up with water. Please check the latest local regulations for the correct disposal of waste product and waste cleaning water.

Acoustic Applications

PROMASEAL®-A Acrylic Sealant has been approved for use with certain acoustic ratings. Please refer to page 30 for the STC value performance levels of the sealant in control joint seals.

Exterior And Fire Resistant Seals In Control Joints

If PROMASEAL®-A Acrylic Sealant has to be used externally, it must be applied in strict accordance with the manufacturer's instructions. The surfaces to which the sealant is to be applied must be dust free to ensure correct adhesion. If there is any doubt about the adhesion of the sealant to the surfaces, prime first by brushing diluted sealant (add approximately 50% water) on to the surfaces.

Backer rod should be inserted into the joint at a position which allows the correct depth of sealant to be applied. It is important to follow the chart provided by the manufacturer for this depth. Do not install the sealant to a depth greater than recommended.

The PROMASEAL® AN Acrylic Sealant must be protected from the elements (e.g. water, freezing etc) until it is fully cured. The curing period will vary depending upon prevailing weather conditions and the size (width or depth) of the joint. Dampness from surrounding building elements can lead to prolonged curing periods.

For maximum long term aesthetic properties, the sealant should have a film preservative (paint) applied over. This coating must be maintained. For exterior use however, such a coating is often not acceptable or even practical. For example, consider maintaining the paint on a multi storey building.

For these and other reasons, Promat does not recommend the use of this product for exterior application. Promat and its official associates will not issue warranties for such exterior applications.

Limitations

It has been demonstrated that occasionally water based sealants develop cracks during the curing cycle for no apparent reason. Conditions during application and immediately thereafter usually contribute to such failures. Acrylic sealant needs to cure at temperatures above 8°C in order to form a uniform seal. Current theory suggests that very porous substrates such as blockwork, combined with low temperatures or high humidity are the prime contributors to failure. This phenomenon may interfere with acoustic performance characteristics but will not affect the fire resisting properties unless the cracking is particularly severe and cracks are pronounced.

After application, the PROMASEAL®-A Acrylic Sealant starts to cure by forming a skin where it is in contact with air. Ordinarily, curing occurs at a rate of about 2mm every 24 hours at 25°C and 5% relative humidity (RH). At low temperatures, however, the curing rate is reduced considerably. When a poorly formed thin skin is tensioned due to the sealant shrinking quickly, the skin can tear away from one edge or split down the middle. The deeper the joint, the greater the likelihood of failure as the skin stretches further in forming a concave finish.

The conventional remedy is to repair the joint by refinishing the affected area with more sealant. It is usually not necessary to cut out and remove the sealant, unless the gap size renders the repair job too difficult.

Promat has a policy of continual improvement through innovative research and development. For confirmation on accuracy of test results, please consult Promat.

Usage For Floors Or Walls Of An Equivalent Fire Resistance Level

To calculate the required PROMASEAL®-A Acrylic Sealant for an application in floors or walls of an equal or greater fire resistance level:

Multiply the joint width (mm) x Joint depth (mm) x Joint length (m)

Divide this result by the required volume of the container, i.e. 300ml, 600ml or 10000ml. See table below for guidance.

Joint size (mm)	Depth of sealant (mm)	Metres per 300mm cartridge	Metres per 600mm foil	Metres per 10 litre pail
10	10	3.0	6.0	100.0
20	10	1.5	3.0	50.0
30	15	0.66	1.33	22.2
40	20	0.38	0.75	12.5
50	25	0.24	0.48	8.0

Typical head and control joints of masonry wall (STC 49)

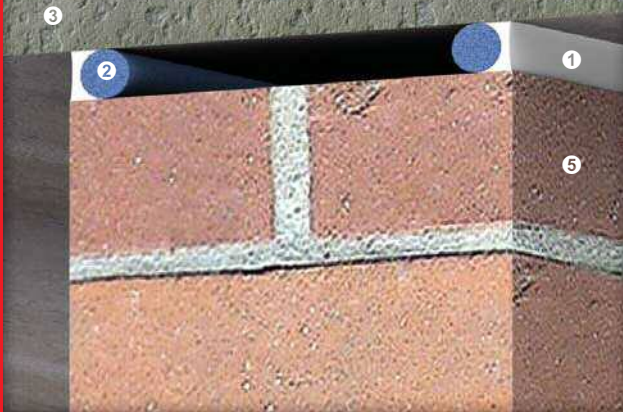

Typical head and control joints of lightweight partition (STC 39)



Typical head and control joints of concrete hollow block wall (STC 45)

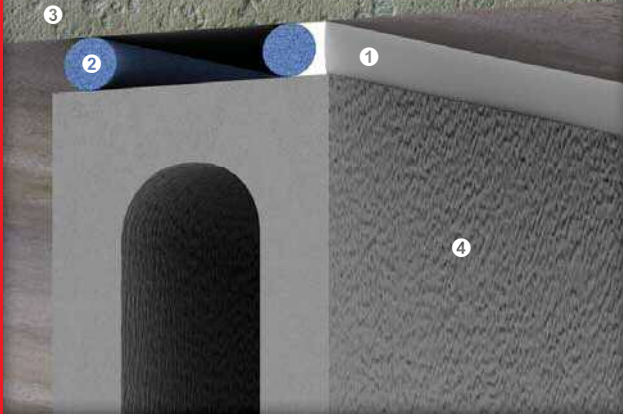

Typical control joints of lightweight partition (STC 45-50)

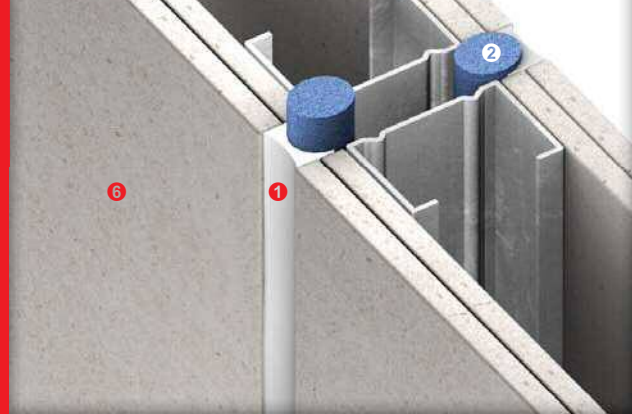

Typical head joints of lightweight partition (STC 45-50)

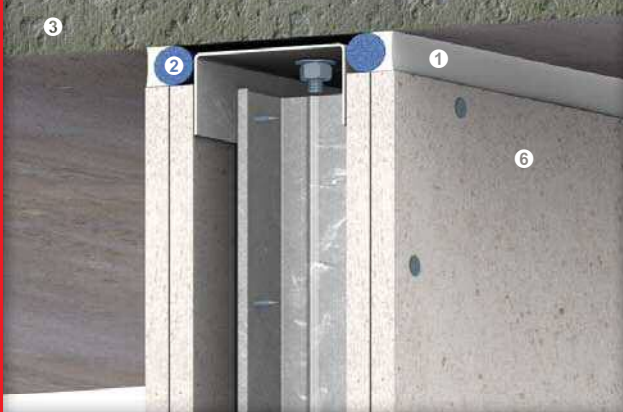

Up to ~240/240 fire resistance in accordance with the requirements of BS 476: Part 20: 1987 and/or AS 1530: Part 4: 2005, depending on applications and types of penetrating elements

- ① PROMASEAL®-A Acrylic Sealant for control joint seals in floors, walls and partitions; STC value performance in accordance with table below
- ② Polyethylene backing rods
- ③ Fire resistant concrete floors
- ④ Fire resistant concrete hollow block walls
- ⑤ Fire resistant masonry walls
- ⑥ Fire resistant steel/timber framed lightweight partitions

STC value performance levels of PROMASEAL®-A Acrylic Sealant in control joints

Typical head and control joints of masonry wall	Typical head and control joints of concrete hollow block wall	Typical head joints of lightweight partition	Typical head joints of lightweight partition with infill	Typical head and control joints of lightweight partition	Typical control joints of lightweight partition	Typical control joints of lightweight partition with infill
Wall STC 49	Wall STC 45	Wall STC 45	Wall STC 50	Wall STC 39	Wall STC 45	Wall STC 50
Joint STC 51	Joint STC 33	Joint STC 47	Joint STC 47	Joint STC 43	Joint STC 41	Joint STC 41
System STC 49	System STC 45	System STC 45	System STC 50	System STC 39	System STC 45	System STC 50

PROMASEAL®-A Acrylic Sealant is a water based acrylic sealant. The advantages of water based sealant is in making post installation and/or site clean up very easy. It is also environmentally friendly. If installed correctly and once cured, PROMASEAL®-A Acrylic Sealant should not crack and it can be simply over painted. It has good resistance to water characteristics and some movement capabilities.

There are, however, some key points to remember:

- PROMASEAL®-A Acrylic Sealant is not recommended as an external water seal.
- It should not be used where continuous water immersion is likely.
- It should not be used in areas where the atmosphere is continually wet or damp, e.g. bathrooms.
- It is not recommended for use in high movement joints. In fact, PROMASEAL®-A Acrylic Sealant should not be employed in joints that require more than $\pm 15\%$ movement.

General Application Considerations

PROMASEAL®-A Acrylic Sealant will adhere to a wide range of surfaces. All common foam backer rods are suitable as bond breakers. Surfaces do not need priming if dust free. If in doubt, apply the diluted (by adding 50% water) PROMASEAL®-A Acrylic Sealant to the surfaces by brush.

PROMASEAL®-A Acrylic Sealant should not be applied if air temperature is below 5°C or above 35°C. If the prevailing ambient temperature is outside this range it may effect the curing of the sealant; the surface temperature of the separating elements must also be taken into consideration.

As a general rule, PROMASEAL®-A Acrylic Sealant when applied around such services as pipes and cables, should not be applied in a gap width greater than 20mm to 25mm. It must also be recognised that sealant has performance limitations and should not be regarded as a “cure all” gap filling solution.

Please refer to [page 32](#) for some typical application details. If the required application is not covered in those details, please consult Promat.

Most applications will have PROMASEAL®-A Acrylic Sealant applied in a symmetrical fashion, e.g. to both sides of the wall and the unexposed top side of the floor. PROMASEAL®-A Acrylic Sealant can extend up to 30mm onto the wall or floor surface and up to 100mm along the cable or pipe, away from the wall or floor.

The depth of the sealant is based upon the available fire test data. The drawings detailed on [page 32](#) show PROMASEAL®-A Acrylic Sealant applied into a gap around services to various depths. The depth can vary, e.g. between 5mm and 32mm deep, other times it may need to be the full depth of the substrate.

Please check with the details of the manufacturers’ fire tests and technical data sheets to ensure the correct minimum or maximum gaps and depths of the sealant is applied.

PROMASEAL®-A Acrylic Sealant can be used in conjunction with other penetration sealing systems such as fire collars, PROMASEAL® Bulkhead Sealer System, PROMASEAL® Mortar, and PROMASEAL® Pillows.

Where insulation criteria is required for services a PROMASEAL® Wrap or mesh guard can be installed.

Wherever services penetrate barrier systems, PROMASEAL®-A Acrylic Sealant should be used in conjunction with the appropriate fire stopping system to ensure there are no small gaps which will allow smoke to penetrate the barrier. In external or wet areas the use of PROMASEAL® Supa Mastic is recommended as an alternative.

The penetration seals of PROMASEAL®-A Acrylic Sealant around floors also assists in stopping the passage of water and/or cold smoke through the floor or wall. However, for permanent water seals appropriate products should be used, e.g. silicones or polyurethanes.

PROMASEAL®-A Acrylic Sealant can also be used as an Acoustic Sealant. This is useful for architects and acoustic engineers working on areas of accommodation, e.g. hotels, offices, residential apartments etc.

PROMASEAL®-A Acrylic Sealant can only maintain the STC rating of the system, which includes the services penetrating the barrier.

Acoustic tests have not been carried out on all services. Therefore applications which require a specific acoustic performance may have to be assessed on their own merits on a case by case basis.

Exterior Penetration Seals Of General Building Services

If PROMASEAL®-A Acrylic Sealant has to be used externally, it must be applied in strict accordance with the manufacturer’s instructions. The surfaces to which the sealant is to be applied must be dust free to ensure correct adhesion. If there is any doubt about the adhesion of the sealant to the surfaces, prime first by brushing diluted sealant (add approximately 50% water) on to the surfaces.

Backer rod should be inserted into the joint at a position which allows the correct depth of sealant to be applied. It is important to follow the chart provided by the manufacturer for this depth. Do not install the sealant to a depth greater than recommended.

The PROMASEAL® AN Acrylic Sealant must be protected from the elements (e.g. water, freezing etc) until it is fully cured. The curing period will vary depending upon prevailing weather conditions and the size (width or depth) of the joint. Dampness from surrounding building elements can lead to prolonged curing periods.

At 25°C and 50% humidity, PROMASEAL®-A Acrylic Sealant will cure at a rate of 2-3mm in depth in the first 24 hours and 1mm in the next 24 hours. Thus a 10mm deep joint will take eight days to fully cure, assuming these ambient conditions are continuous.

For maximum long term aesthetic properties, the sealant should have a film preservative (paint) applied over. This coating must be maintained. For exterior use however, such a coating is often not acceptable or even practical. For example, consider maintaining the paint on a multi storey building.

For these amongst other reasons, Promat does not recommend the use of this product for exterior use. Promat and its official associates will not issue warranties for such exterior applications.

PROMASEAL® Supa Mastic

PROMASEAL® Supa Mastic is a one part polyurethane based sealant suitable for external and wet area applications. Installation as well as the approvals are similar to those prescribed for PROMASEAL®-A Acrylic Sealant. Please consult Promat for more details as the approvals for this new product are increasing at all times.

Electrical cables and cable tray passing through lightweight partition

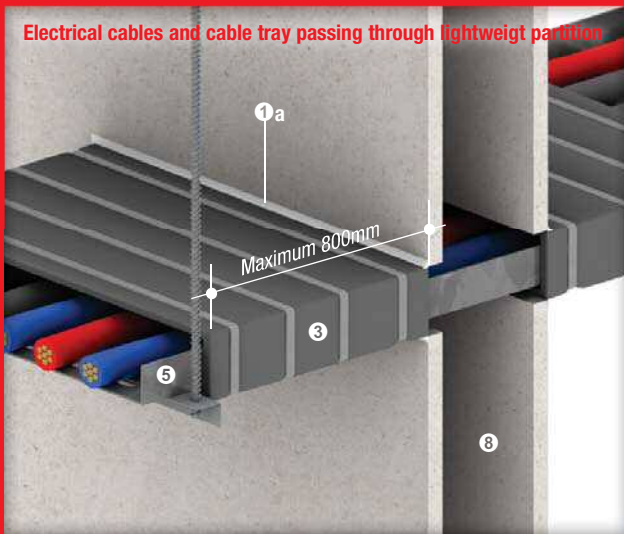

Bunch of electrical cables penetrating concrete floor

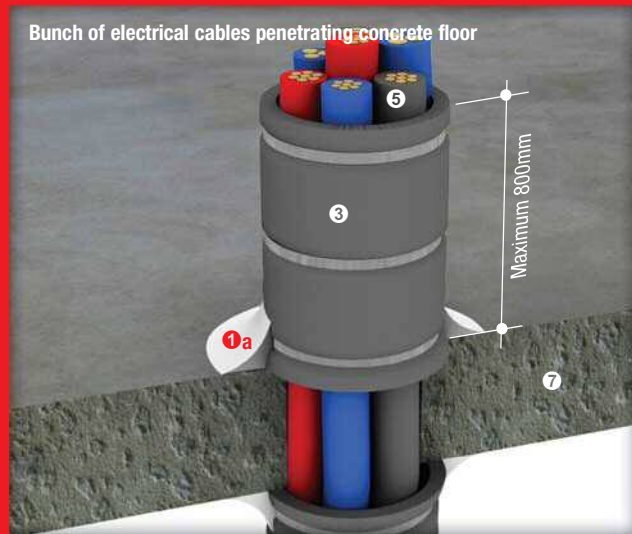

Bundle of electrical cables passing through lightweight partition

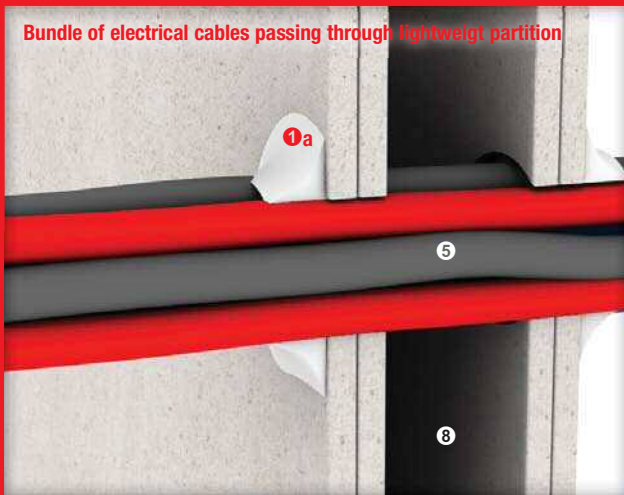

Metal pipe passing through lightweight partition

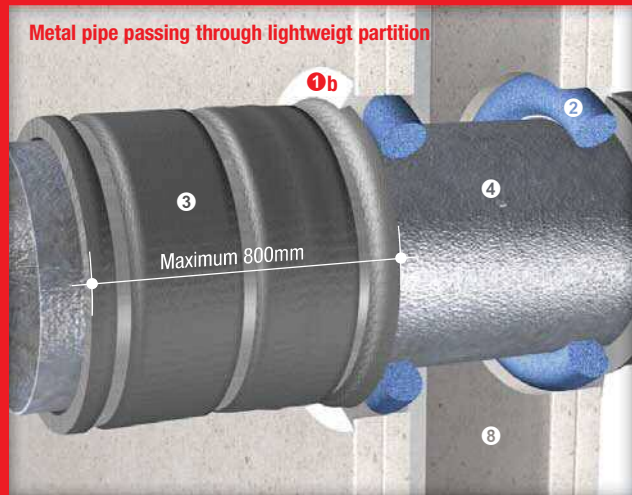

Metal pipe penetrating concrete floor

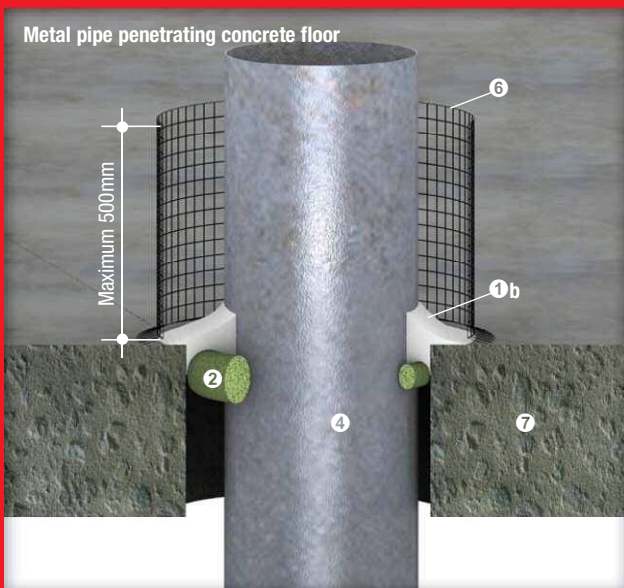

Up to -/240/- fire resistance in accordance with the requirements of BS 476: Part 20: 1987 and/or AS 1530: Part 4: 2005, depending on applications and types of penetrating elements

- ①a PROMASEAL®-A Acrylic Sealant for penetration seals of electrical cables and cable trays (up to -/180/- fire resistance) in floors and partitions
- ①b PROMASEAL®-A Acrylic Sealant for penetration seals of cored hole-fixed metal pipes (up to -/120/- fire resistance) or cast-in metal pipes (up to -/240/- fire resistance) in floors and partitions
- ② Polyethylene backing rods (or PROMASEAL® IBS™, see pages 35 and 36)
- ③ PROMASEAL® Wrap
- ④ Non combustible metal pipes* up to 150mm nominal diameter
- ⑤ Electrical cables with or without supporting cable tray/steel trunking
- ⑥ Steel wire mesh to maintain distance from combustible materials where insulation criteria is required (please consult Promat for details)
- ⑦ Fire resistant concrete floors
- ⑧ Fire resistant steel/timber framed lightweight partitions

All above penetraton sealing systems apply equally to concrete, masonry, plasterboard and dry construction materials (e.g. PROMATECT®-H, PROMATECT® 50, PROMATECT® 100 and PROMINA® 60) where the structure has a fire resistance level equal or greater than the proposed system

*Use of copper pipes instead might affect the overall fire resistance performance of the penetration seal due to the fact that copper is a high conductor of heat. Please consult Promat for application of PROMASEAL®-A Acrylic Sealant on penetration seals of copper pipes